



**classic**  
architectural group

For Every Step®

## Installation Guide

# EziStax Max - Dynamic 2-Tier Sliding Upper and Lower







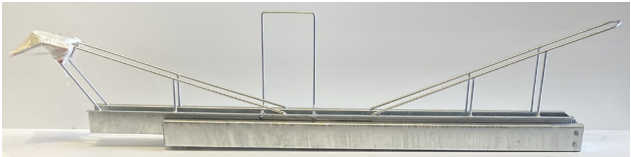
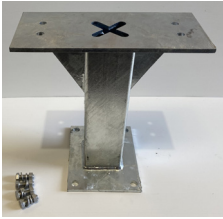

## Installation Guide

# EziStax Max - Dynamic 2-Tier Sliding Upper and Lower

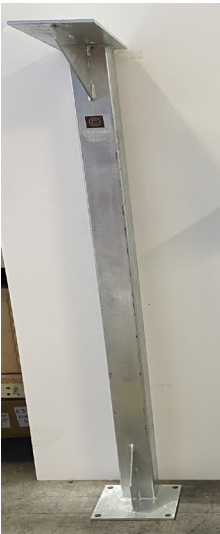
### Parts & Fittings

QTY	DESCRIPTION	QTY	DESCRIPTION
2	DYNAMIC TOP TIER RACK 	2	DYNAMIC BOTTOM TIER RACK 
1	BOTTOM TIER DYNAMIC ELEVATED BASE PLATE & BOLTS 1 x Elevated Base Plate 4 x Bolts 	1	BOTTOM TIER DYNAMIC LOW BASE PLATE & BOLTS 1 x Base Plate 4 x Bolts 
1	HIGH POST (1540mm) 4 x M10x30mm bolts & nuts per post 	1	LOW POST (1240mm) 4 x M10x30mm bolts & nuts per post 



**classic**  
architectural group

**For Every Step®**

## Installation Guide

# EziStax Max - Dynamic 2-Tier Sliding Upper and Lower

### Tools Required

---

- Hammer
- Masonry Drill
- 16mm Masonry bit and 12mm Masonry bit
- Socket Set x 2 (including 24mm, 19mm, 17mm & 14mm socket)
- Threadlocker Fluid
- Air Compressor

### Important Notes

---

- Installing a 2 Tier Dynamic Bike Rack is a 2 person job
- Each rack will take approximately 35mins to install
- Racks can only be installed on level ground
- Familiarise yourself with the whole assembly document before proceeding.
- We also suggest that you assemble a set as a 'dry run' to familiarise yourself with the assembly, and to check and confirm the final set-out and placement of the racks before fixing them to the ground



## Installation Guide

# EziStax Max - Dynamic 2-Tier Sliding Upper and Lower

### Step 1 - Layout Posts and Base Plates

- Follow below floor plan and measurements to layout the high and low posts, and base plates.

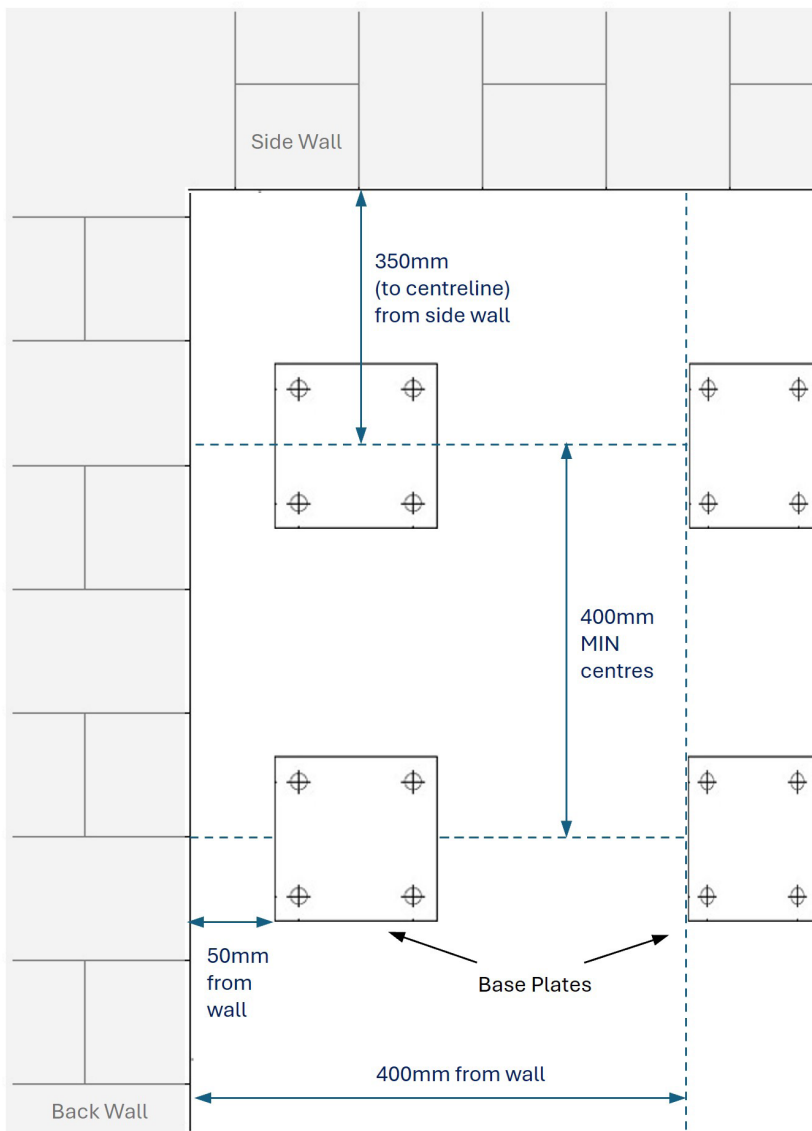



## Installation Guide

# EziStax Max - Dynamic 2-Tier Sliding Upper and Lower

### Step 2 - Floor Layout & Checking Ceiling Height Clearance

#### FLOOR LAYOUT

- You must alternate the heights of the posts and the base plates
- Allow 400mm centres between posts
- Where a post is next to a wall, allow 350mm from the wall to the centreline of the first base plate

#### CEILING HEIGHT CLEARANCE

- The minimum clearance height required for a high post unit is 2800mm, the minimum clearance height required for a low post unit is 2500mm
- Ensure you check ceiling heights and clearance, and plan whether you need to start with a high or low post

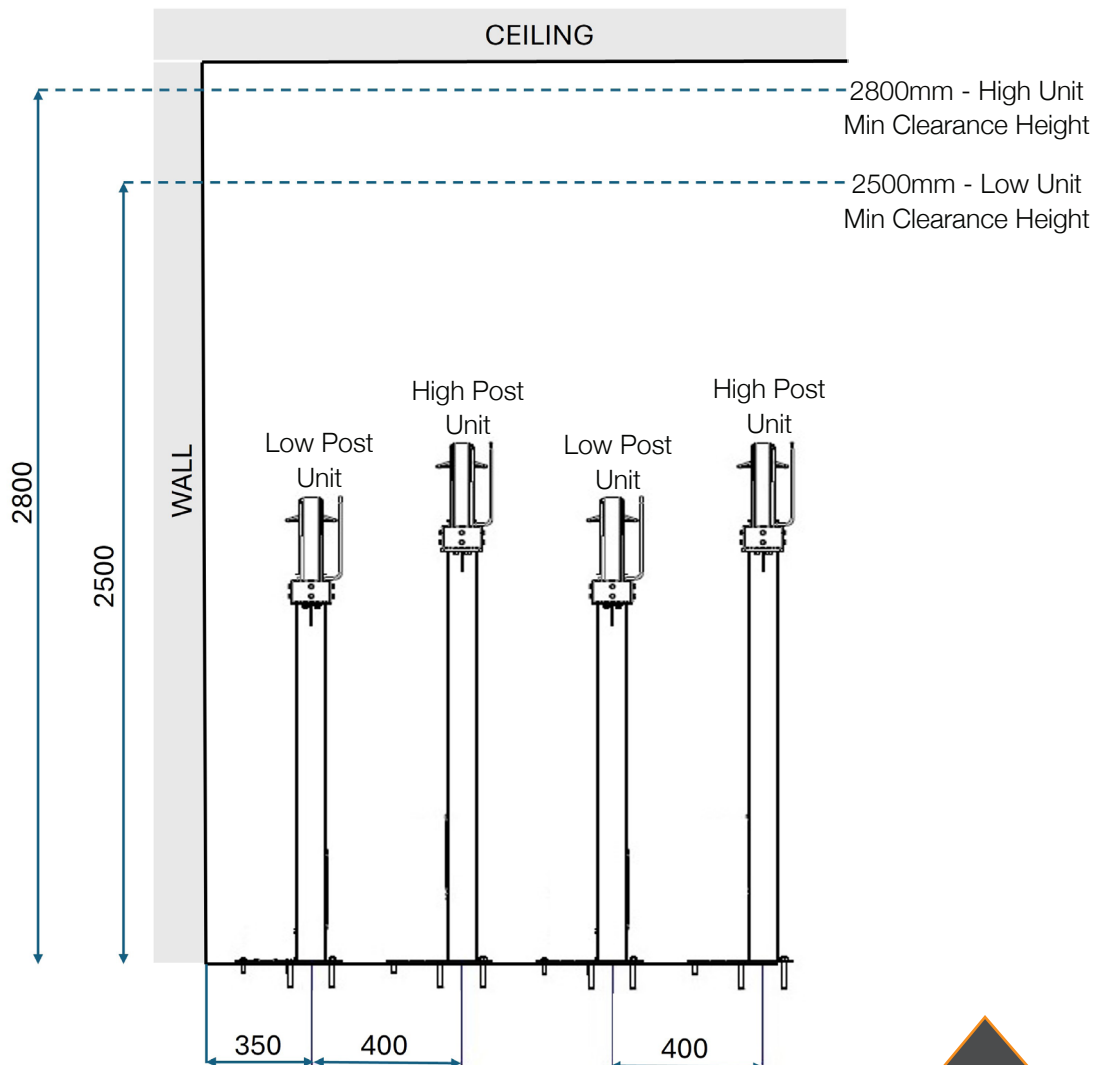



## Installation Guide

# EziStax Max - Dynamic 2-Tier Sliding Upper and Lower

### Step 3 - Ensure a 2m Clearance Zone Behind Racks

All 2 Tier Bike Racks MUST include a 2m Clearance Zone or Access Aisle behind the racks, see below diagram. This is an Australian Standard requirement. It ensures users can easily load and unload their bikes.

Racks can be angled for smaller width rooms

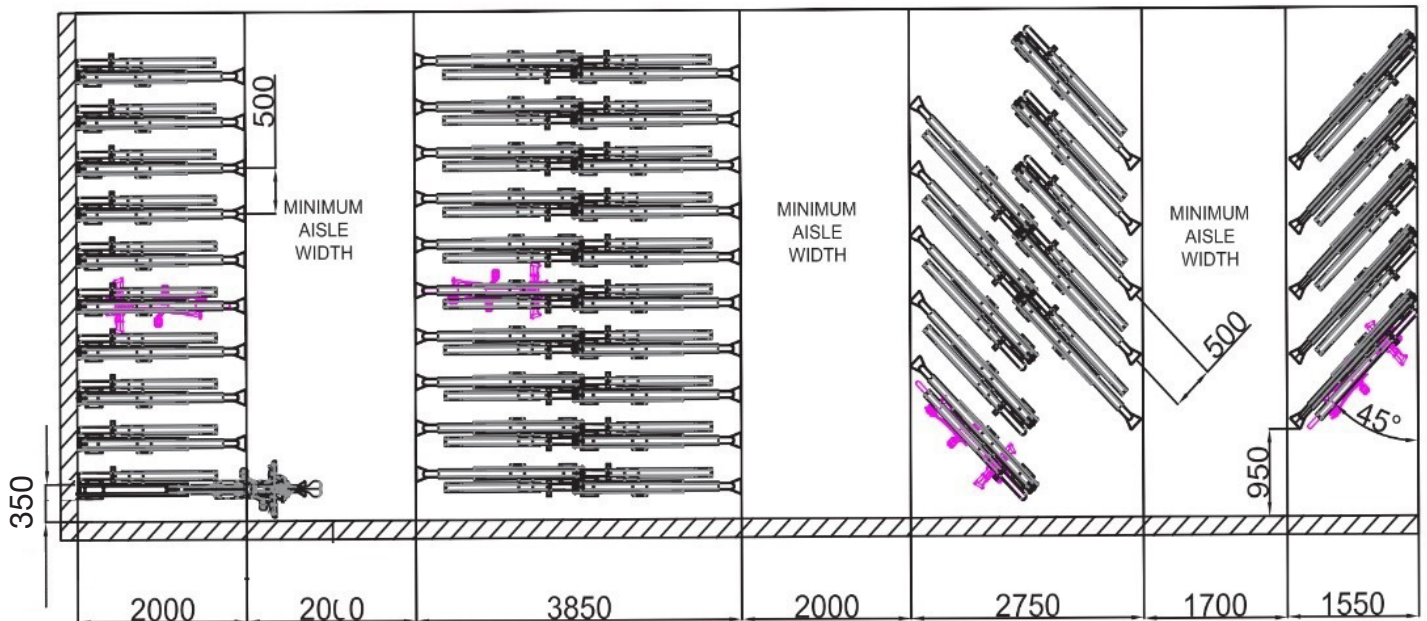



## Installation Guide

# EziStax Max - Dynamic 2-Tier Sliding Upper and Lower

### Step 4 - Fix Posts to the Substrate

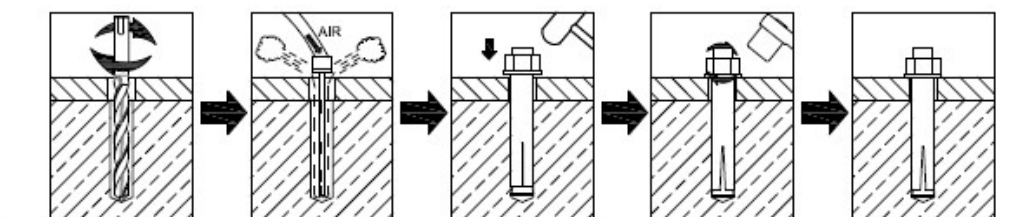
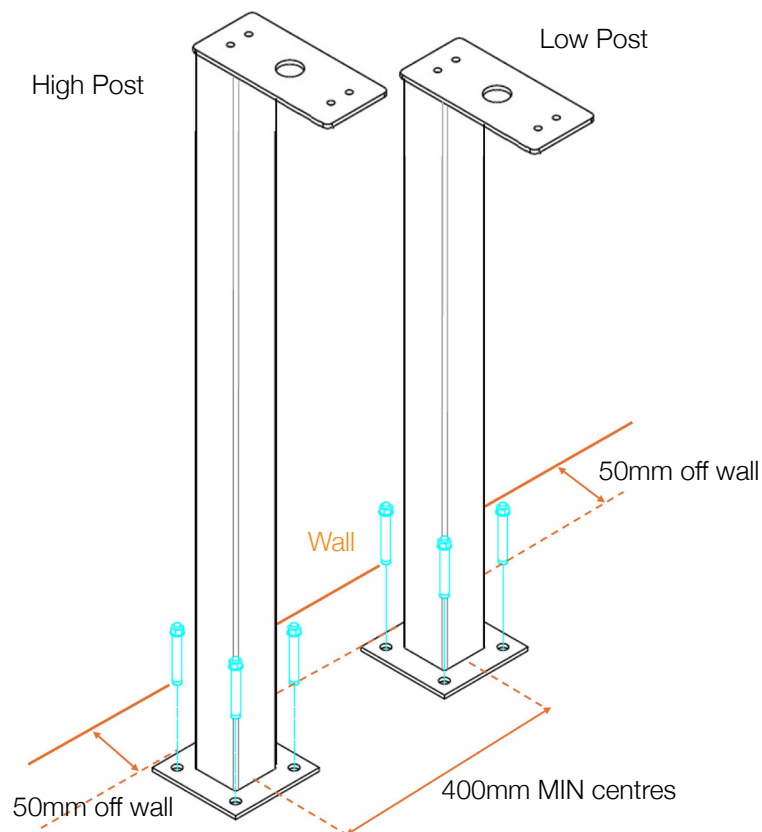





## Installation Guide

# EziStax Max - Dynamic 2-Tier Sliding Upper and Lower

### Step 5 - Fix Bottom Tier Base Plates to the Substrate

- High post should be paired with the elevated base plate, the low post should be paired with the low base plate (see image)

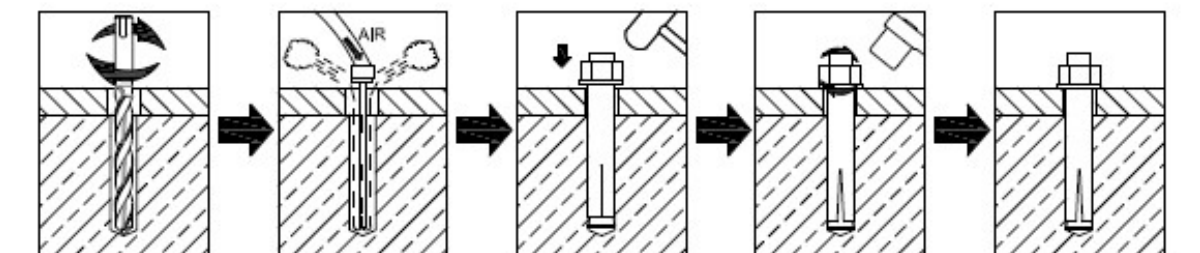
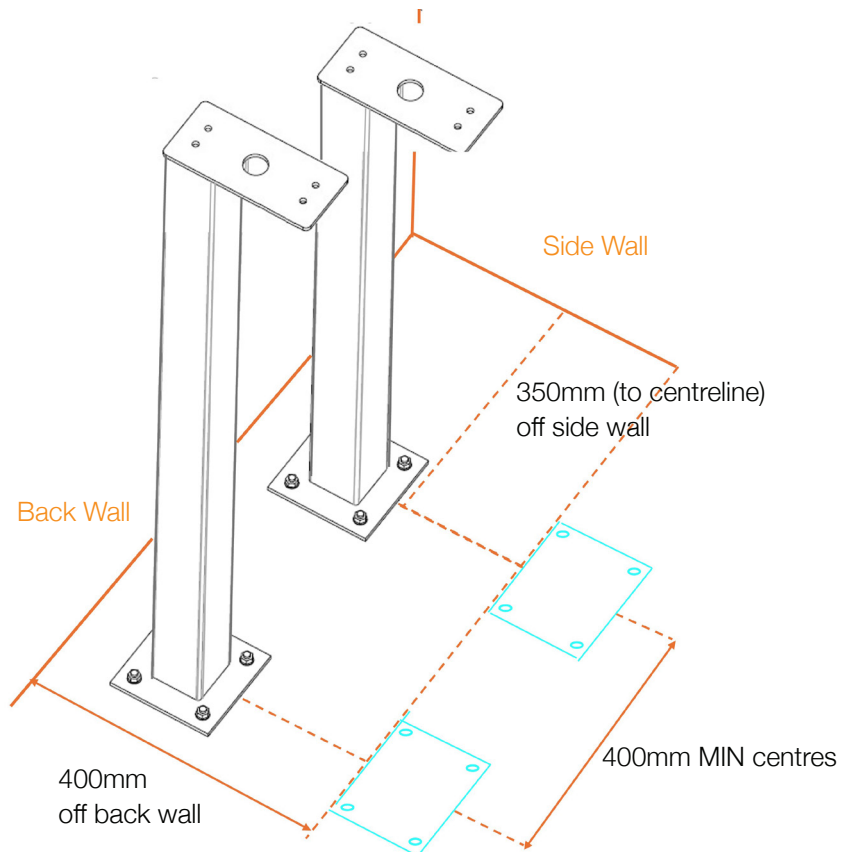





## Installation Guide

# EziStax Max - Dynamic 2-Tier Sliding Upper and Lower

### Step 6 - Mount Sliding Top Teir Rack to Posts

Sliding →

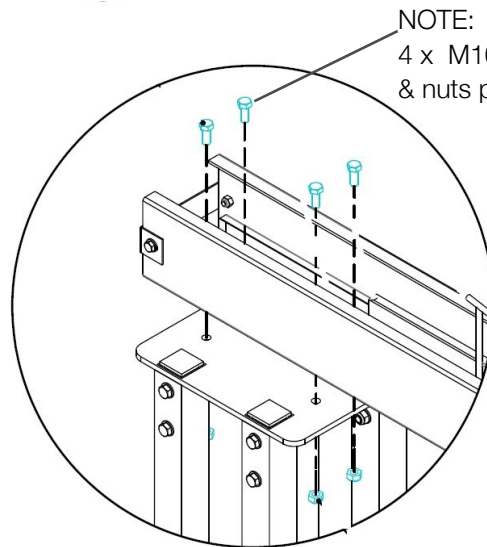
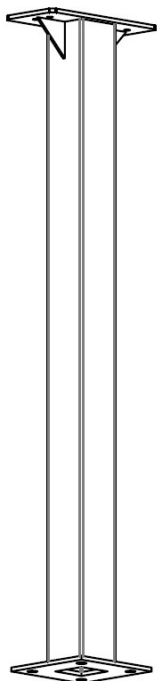
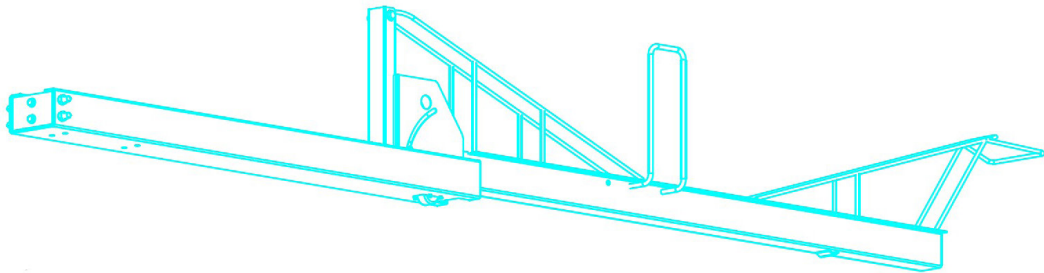
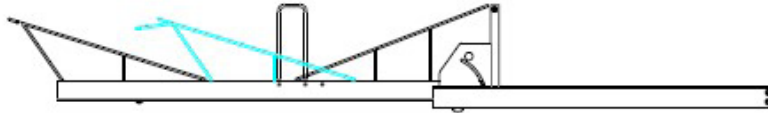

NOTE:  
4 x M10x30 bolts  
& nuts per post

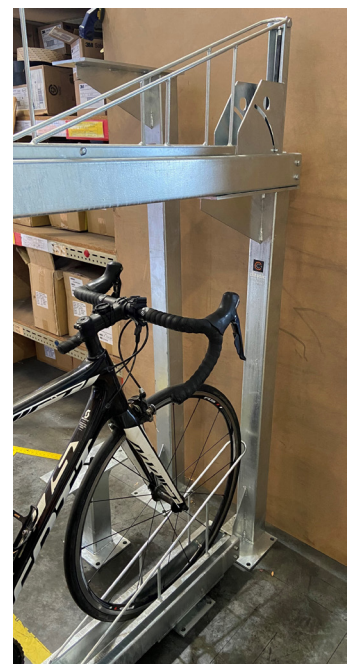



**classic**  
architectural group

For Every Step®

## Installation Guide

# EziStax Max - Dynamic 2-Tier Sliding Upper and Lower

## Step 7 - Mount Sliding Bottom Tier Rack to Base Plates

NOTE:  
4 x M10x30 bolts  
& nuts per post

