



classic
architectural group

For Every Step®

Installation Guide

DoubleDeck Bike Rack

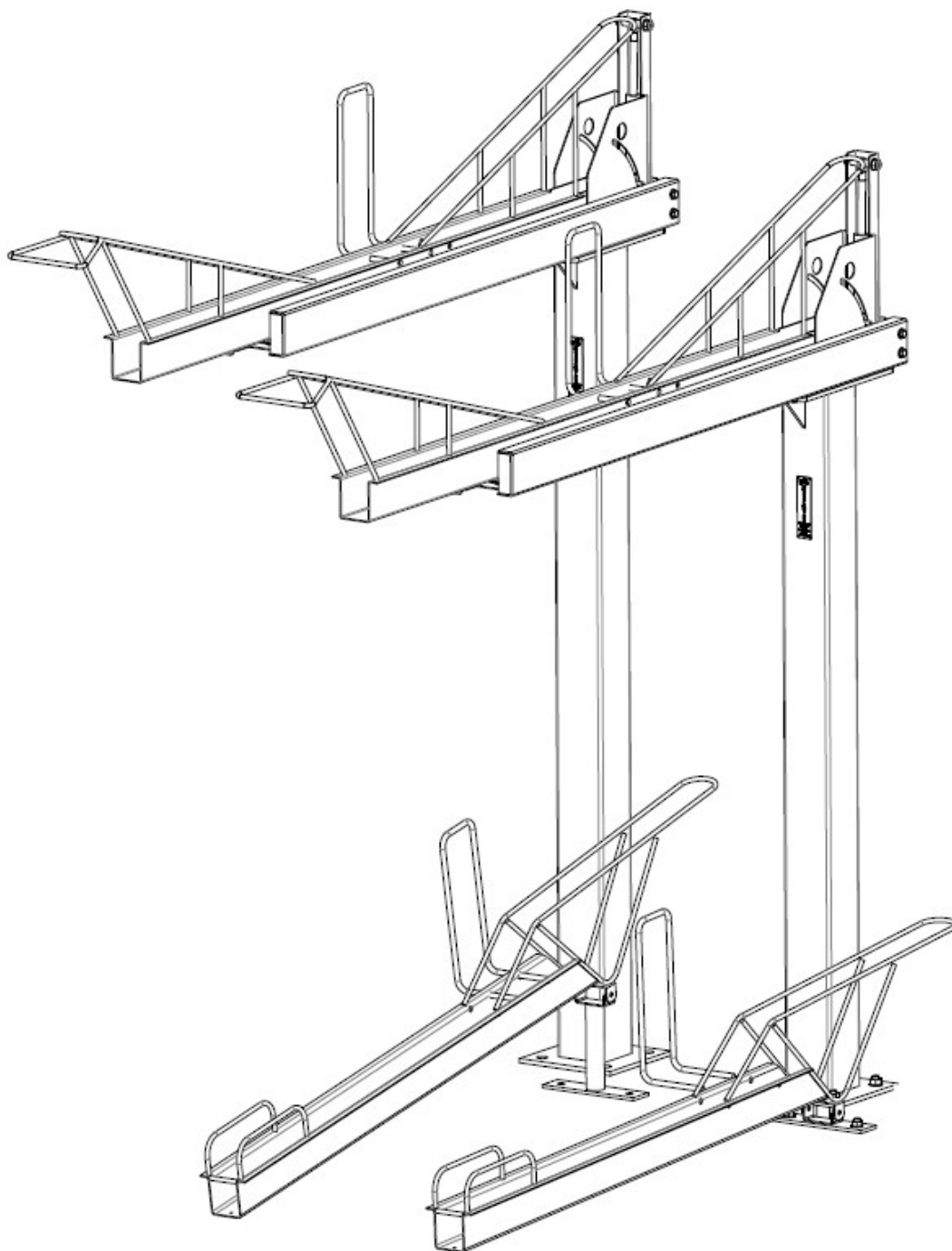



Installation Guide

DoubleDeck Bike Rack

Parts & Fittings

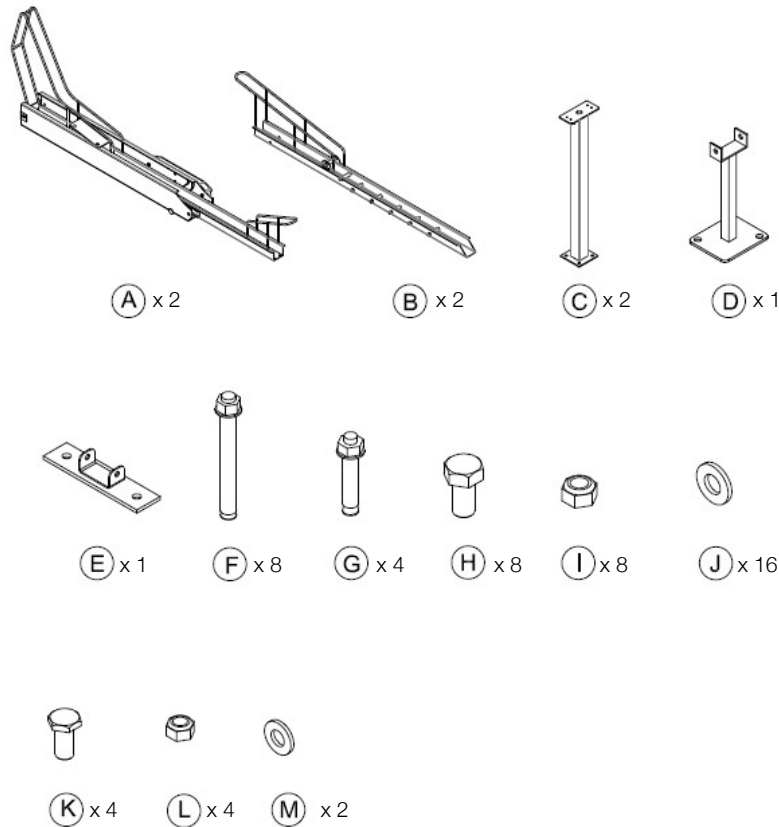

Parts & Fittings

NO.	QTY	DESCRIPTION	NO.	QTY	DESCRIPTION
A	2	Top Wheel Track	H	8	SS304 Hex Bolt M10x25mm
B	2	Bottom Wheel Track	I	8	SS304 Nylon Hex Nut M 10
C	2	Main Post (Low Unit Post - 1240mm, High Unit Post - 1530mm)	J	16	Plastic Washer round M 10
D	1	Base Plate B (For CBR2GSB Only)	K	4	SS304 Hex Bolt M8x25mm
E	1	Base Plate A (For CBR2GSA Only)	L	4	SS304 Nylon Hex Nut MB
F	8	Dynabolt 16mm(M 12)x110mm	M	8	Plastic Washer round MB
G	4	Dyna bolt 12mm(M 1 O)x60mm			



classic
architectural group

For Every Step®

Installation Guide

DoubleDeck Bike Rack

Tools Required

- Hammer
- Masonry Drill
- 16mm Masonry bit and 12mm Masonry bit
- Socket Set x 2 (including 24mm, 19mm, 17mm & 14mm socket)
- Threadlocker Fluid
- Air Compressor

Important Notes

- Installing a 2 Tier Dynamic Bike Rack is a 2 person job
- Each rack will take approximately 35mins to install
- Racks can only be installed on level ground
- Familiarise yourself with the whole assembly document before proceeding.
- We also suggest that you assemble a set as a 'dry run' to familiarise yourself with the assembly, and to check and confirm the final set-out and placement of the racks before fixing them to the ground



classic
architectural group

For Every Step®

Installation Guide

DoubleDeck Bike Rack

Step 1 - Measurements & Set Out - Clearance & Access

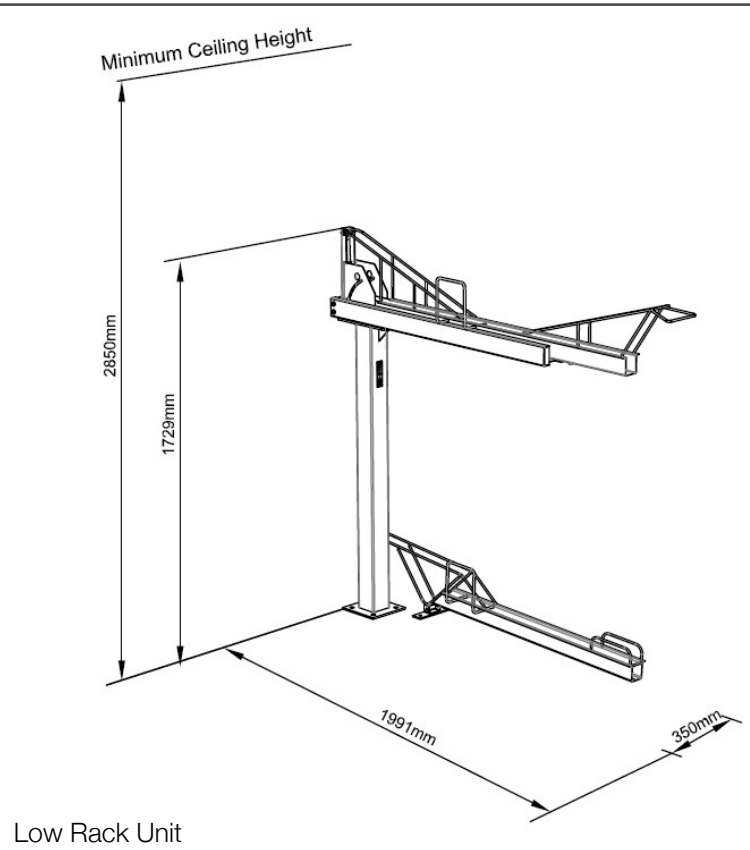
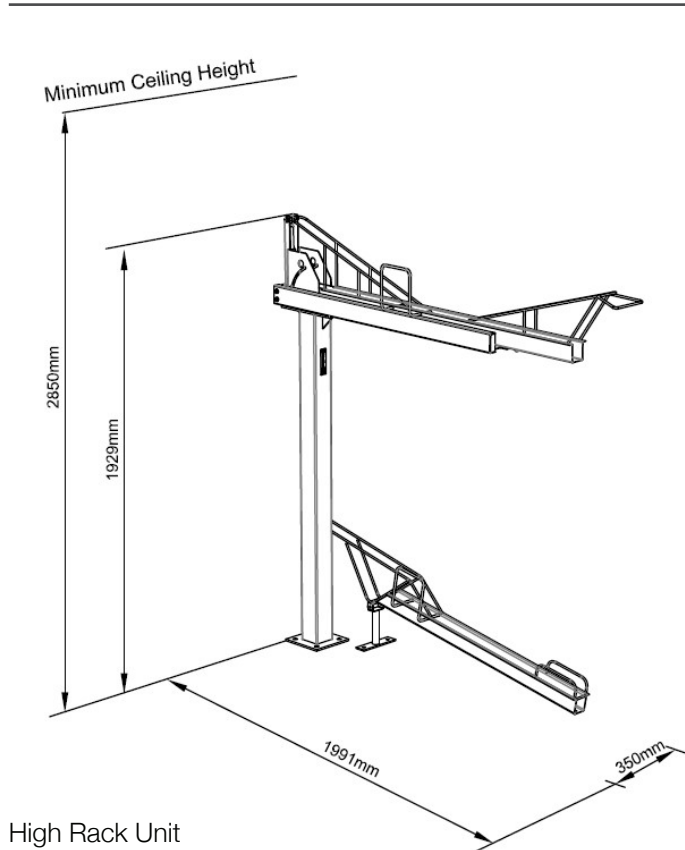



Installation Guide

DoubleDeck Bike Rack

Step 2 - Required Rack Spacing

NOTE: This view is from the WALL SIDE looking out into the bike parking area.

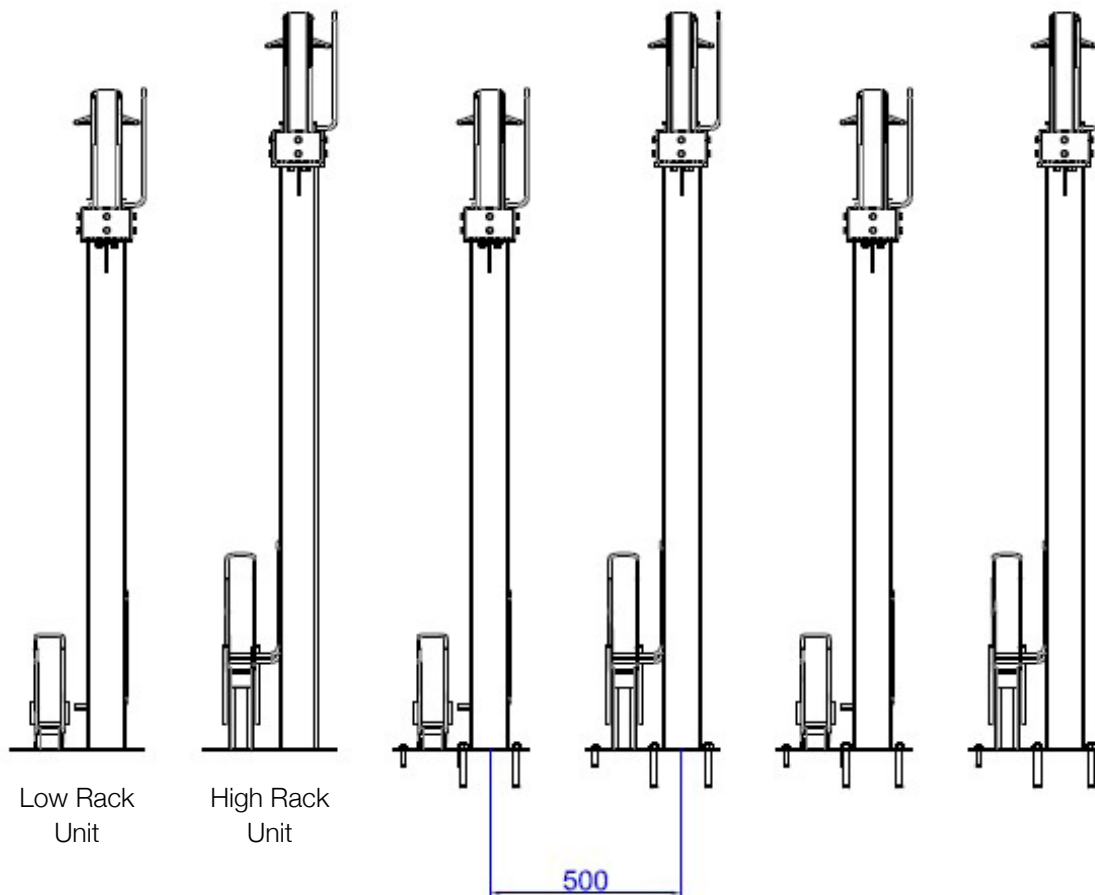



Installation Guide

DoubleDeck Bike Rack

Step 2 - Required Rack Spacing

Racks can be angled for smaller width rooms

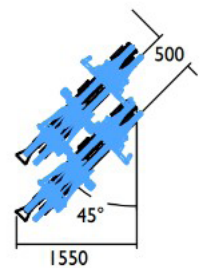
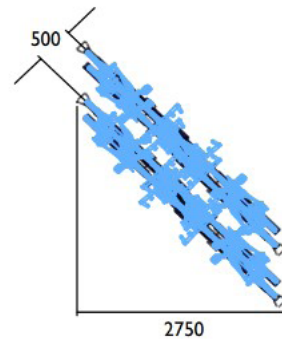
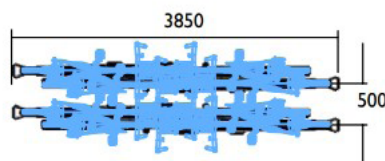
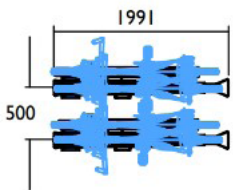
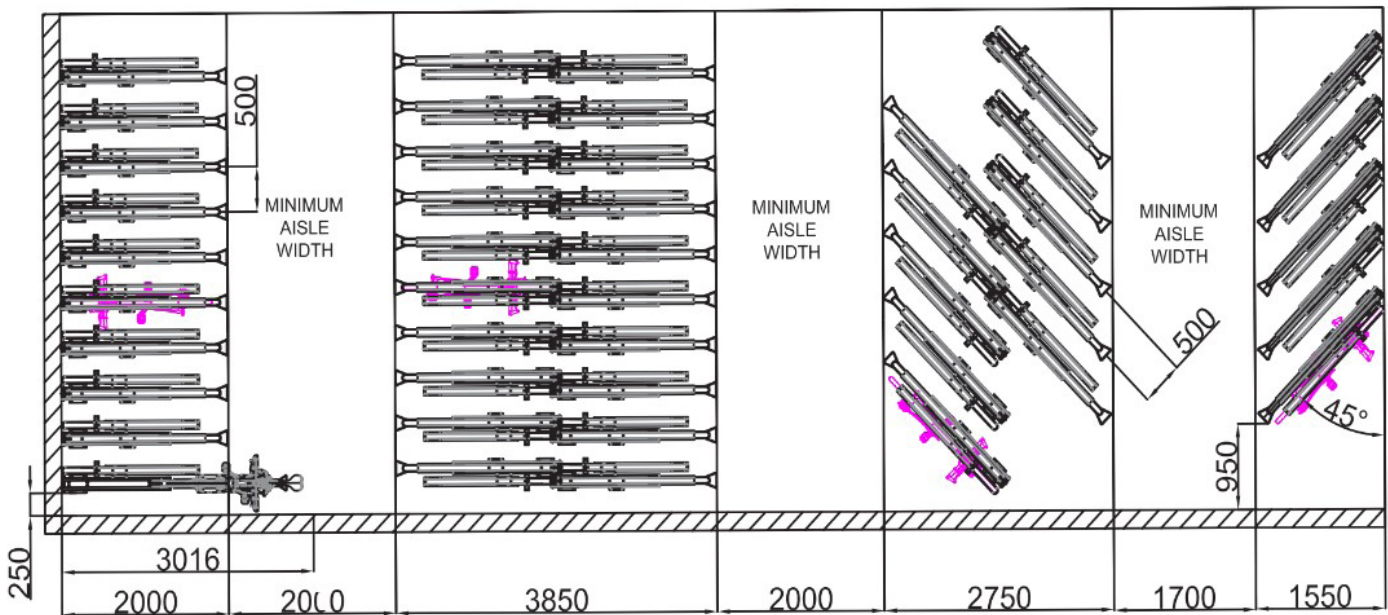



classic
architectural group

For Every Step®

Installation Guide

DoubleDeck Bike Rack

Step 3 - Fix Main Posts to the Ground

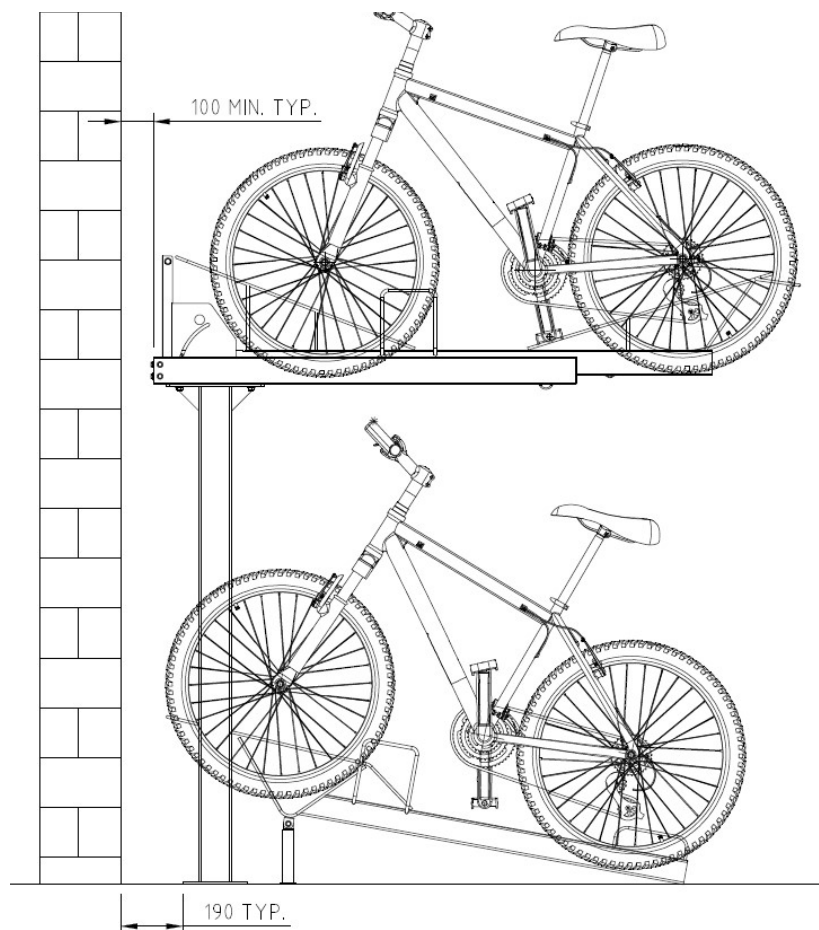



Installation Guide

DoubleDeck Bike Rack

Step 3 - Fix Main Posts to the Ground

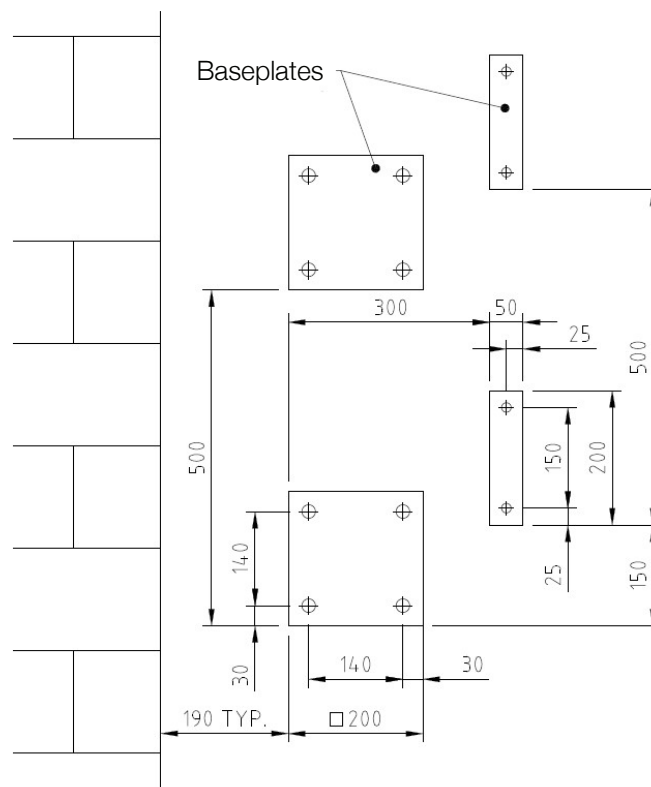
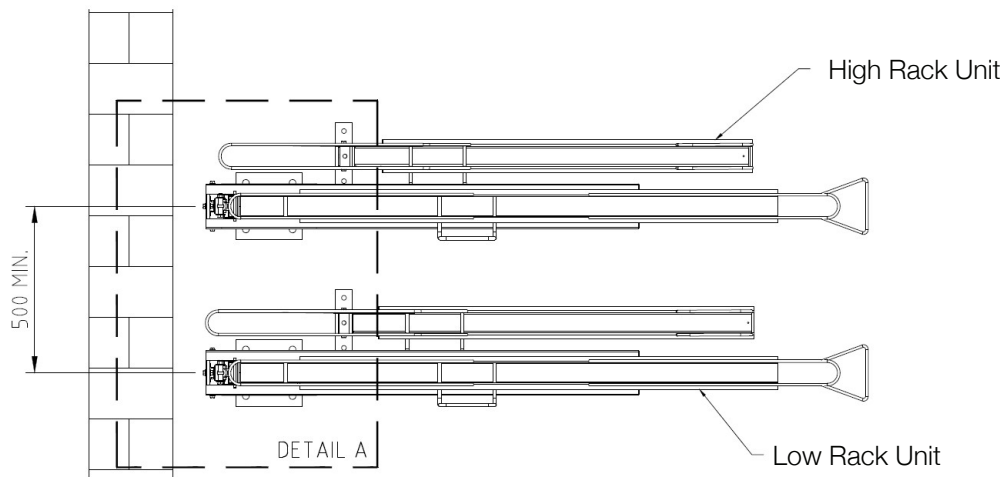

DETAIL A
SCALE 1:5



Installation Guide

DoubleDeck Bike Rack

Step 3 - Fix Main Posts to the Ground

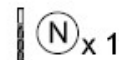
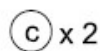
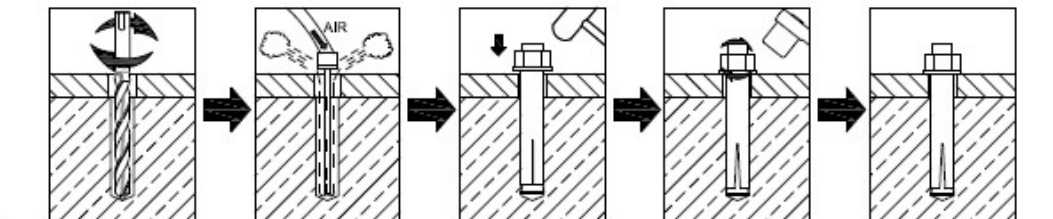
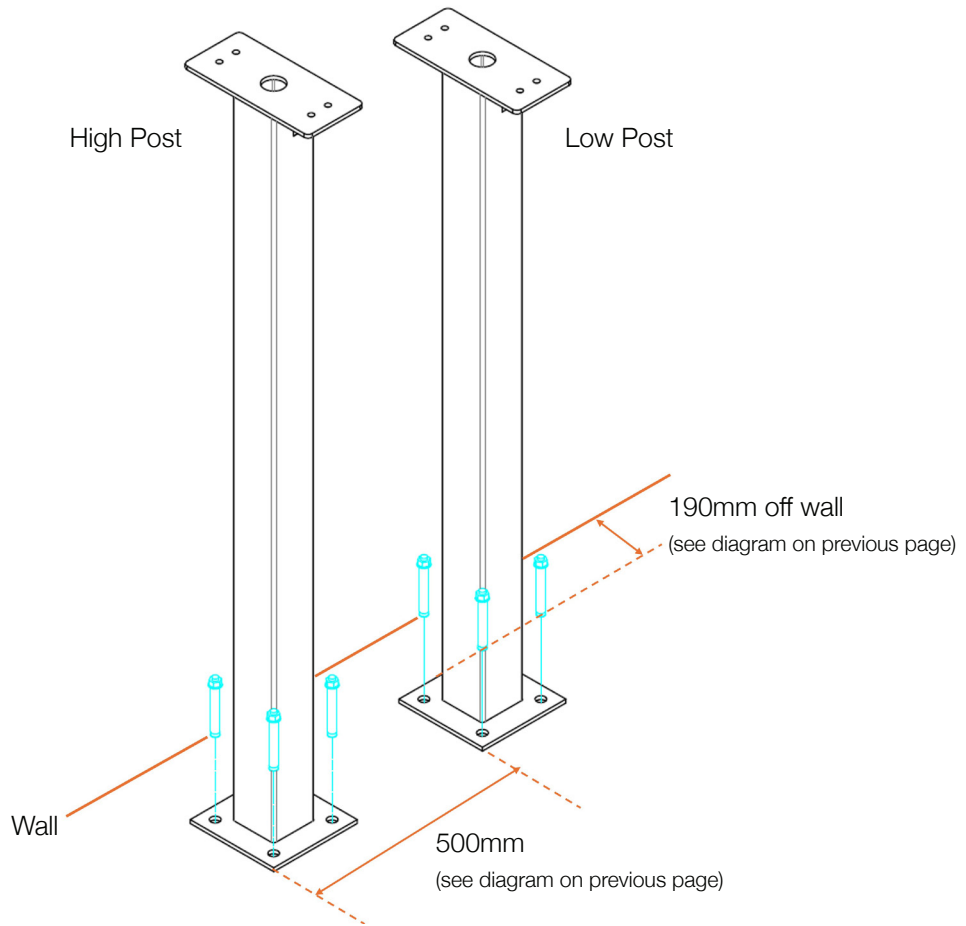



Installation Guide

DoubleDeck Bike Rack

Step 4 - Fix Lower Rail Brackets to Ground

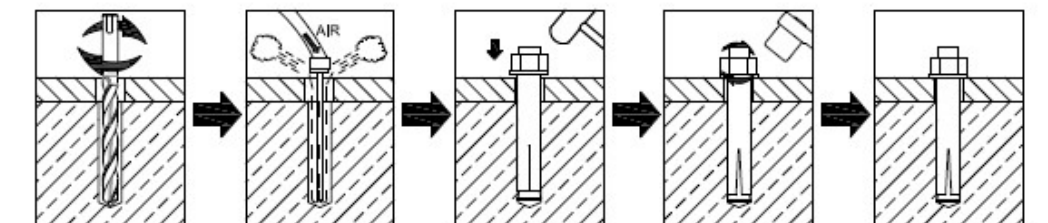
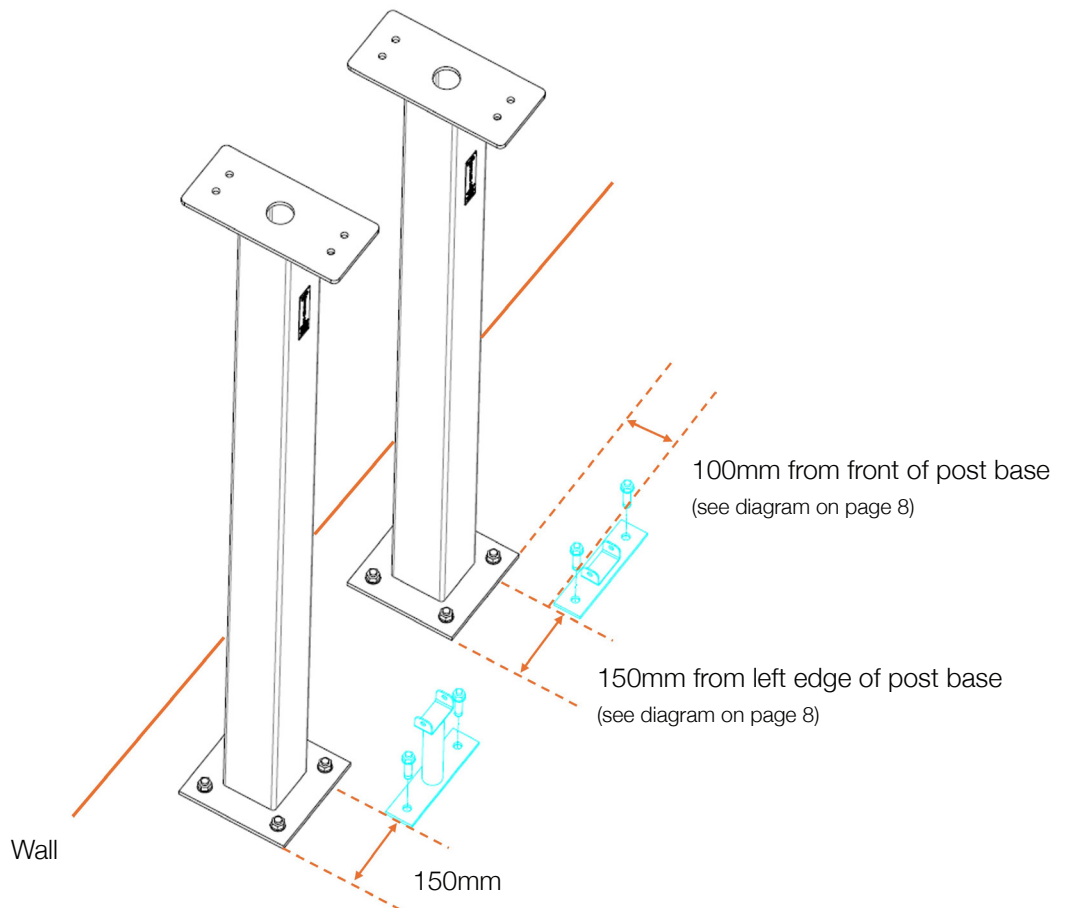

ⓓ x 1

ⓔ x 1

Ⓞ x 1



ⓖ x 4

17mm x 1





Installation Guide

DoubleDeck Bike Rack

Step 5 - Mount Sliding Upper Rack Assemblies to Posts

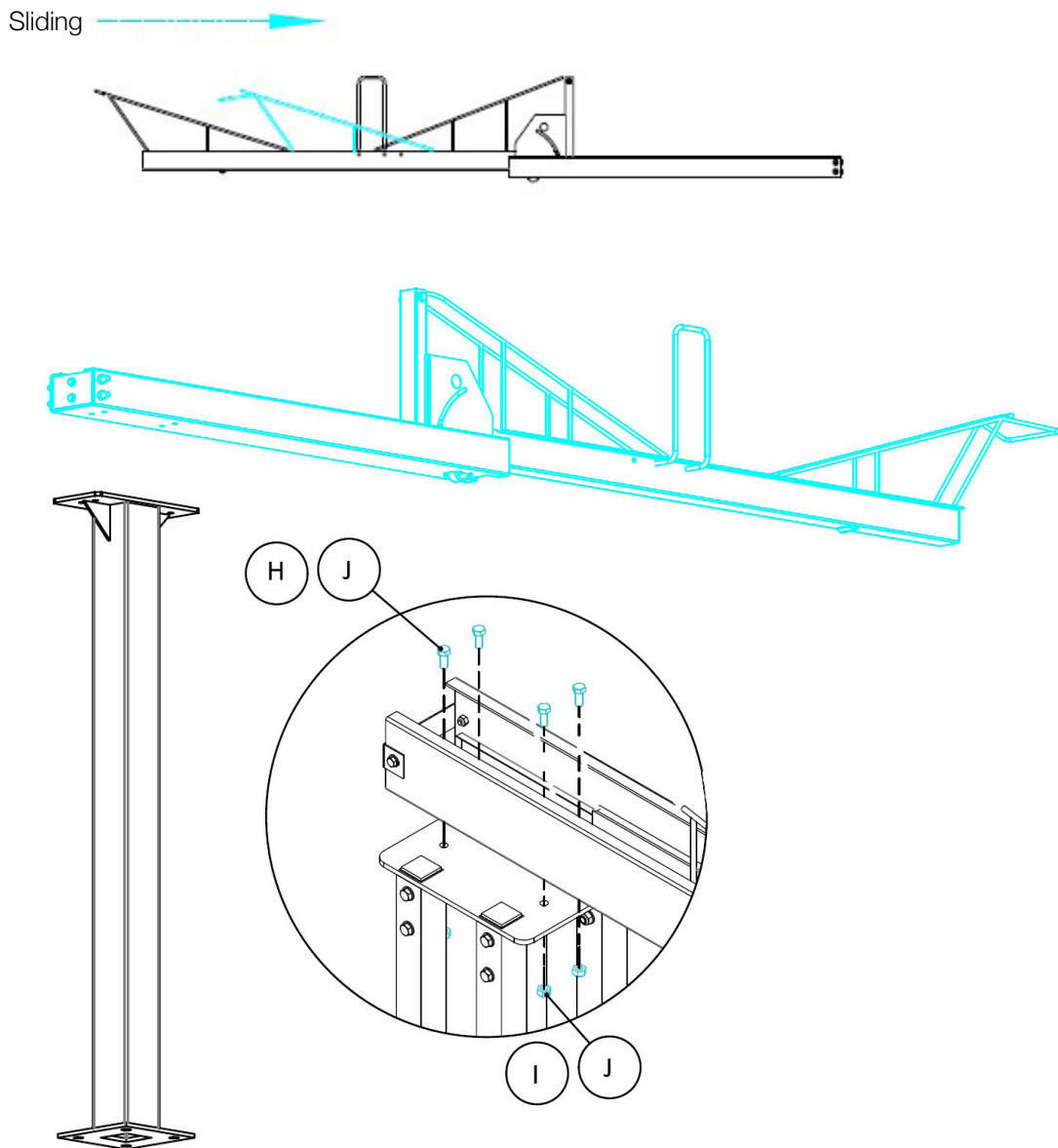

⚙️ (H) x 4

(A) x 1

⊙ (J) x 8

⊙ (I) x 4

🔩 x 1

🔧 17mm x 2

🧑 x 2



Installation Guide

DoubleDeck Bike Rack

Step 6 - Mount Lower Rail Assemblies to Ground Brackets

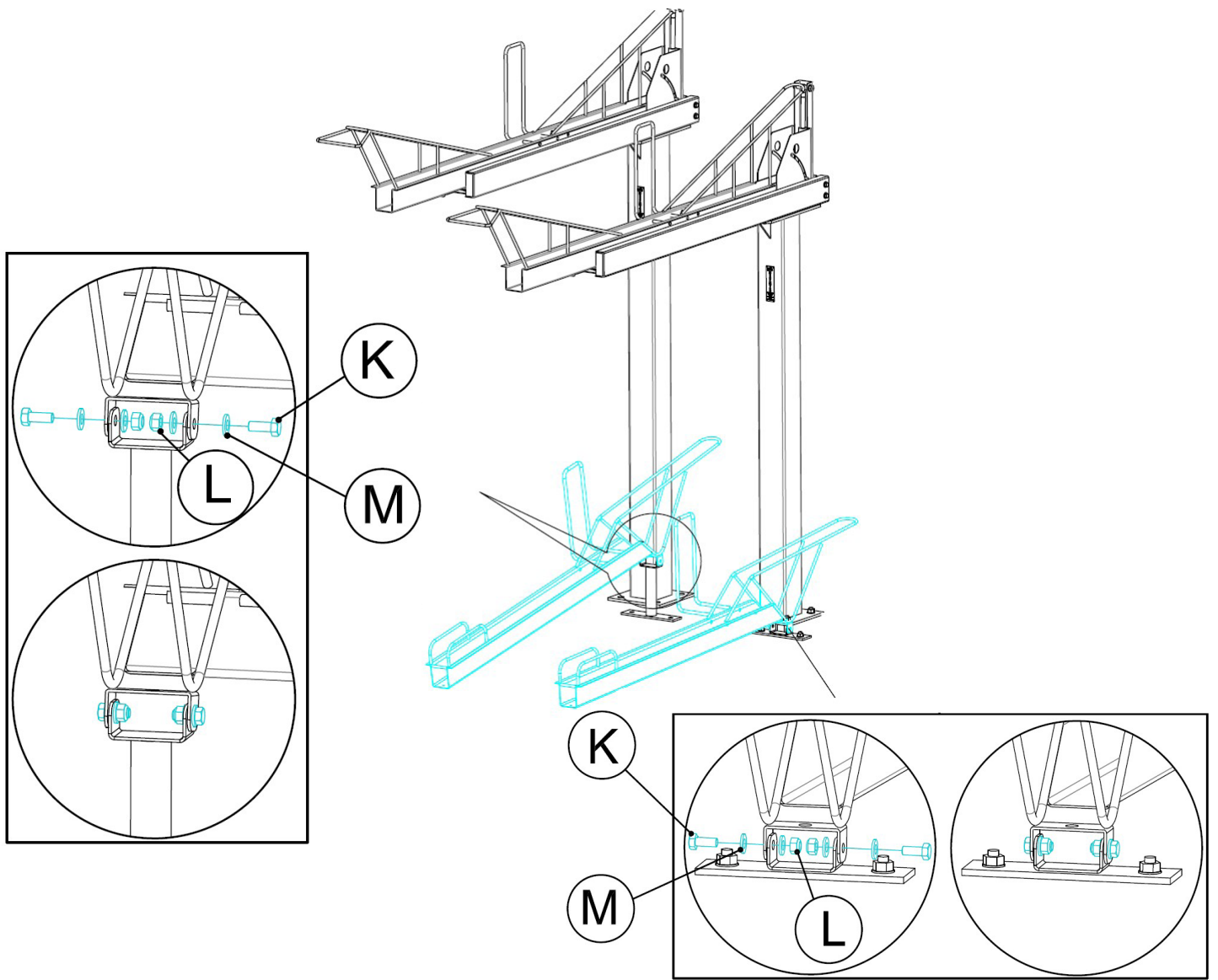

ⓑ x 2

Ⓛ x 4

Ⓜ x 1

Ⓚ x 4

Ⓜ x 8

Ⓜ 19mm x 1

