



**classic**  
architectural group

For Every Step®

## Installation Guide

# MultiPark Bike Rack - Coat Hanger

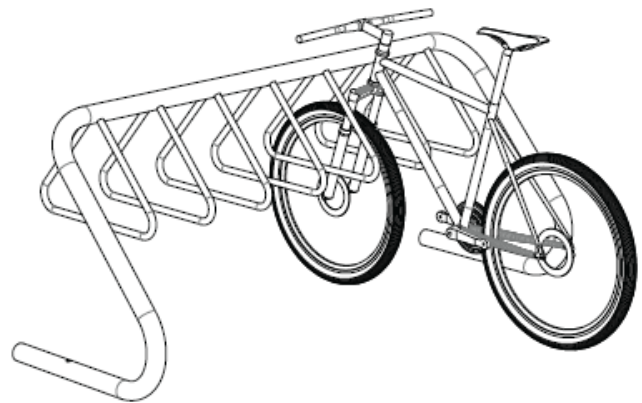
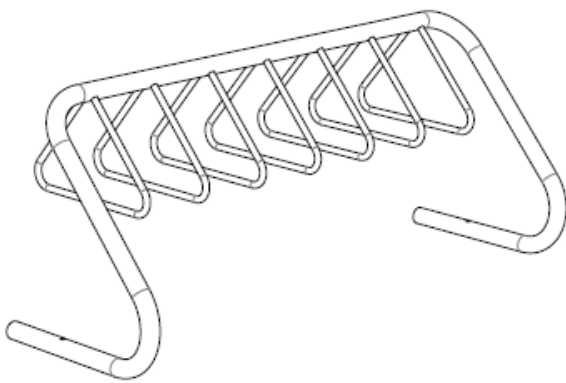

## Access & Clearance

The Coat Hanger Style bike rack can be positioned to allow single or double sided access. Where space permits, try to allow double sided access as it increases the rack's maximum capacity.

Single side access:

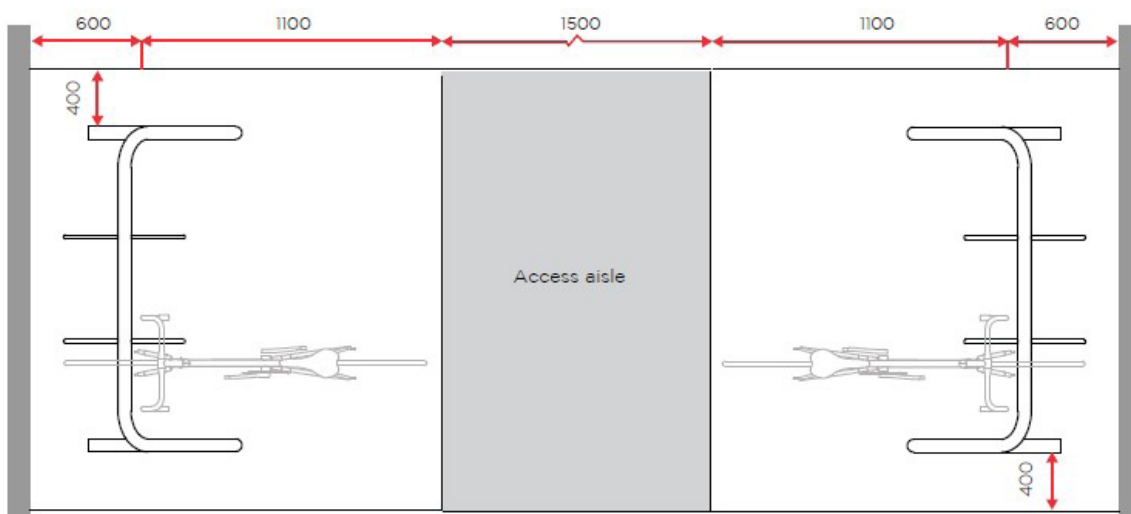



## Installation Guide

# MultiPark Bike Rack - Coat Hanger

Double side access:

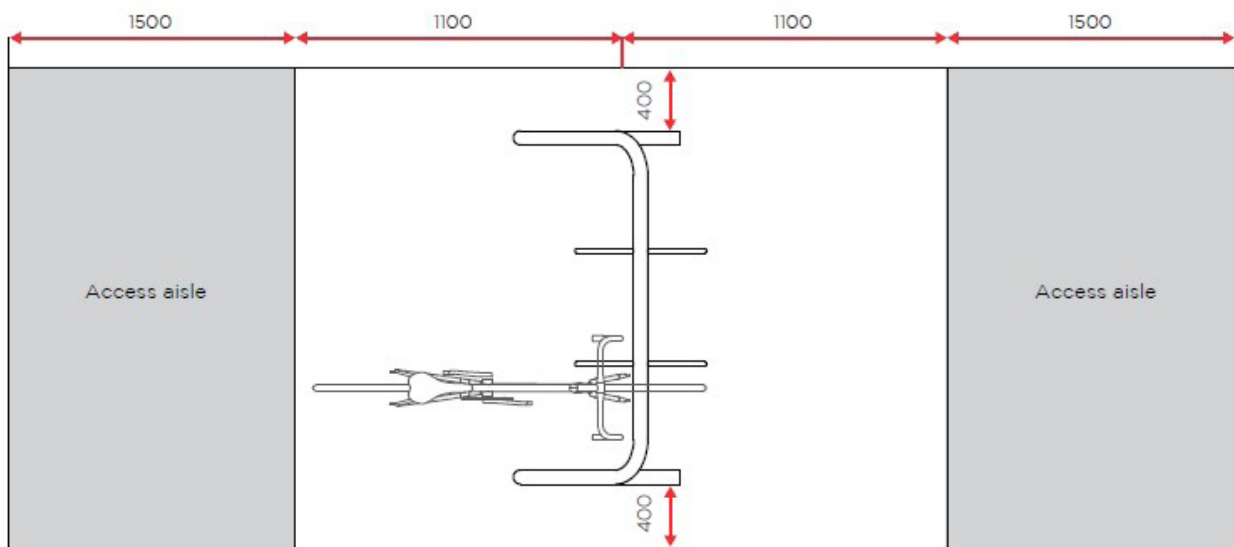

Access dimensions around racks

- Before mounting rack, find a suitable place that will allow for minimum spacing dimensions
- Ensure min distance of 1500mm is provided for correct aisle space and access for bikes
- Ensure minimum spacing from walls, other racks or obstructions to allow for minimum access
- In multiple rack instal, racks may be mounted in an in-line cluster or a parallel cluster

## Fixings - Concrete Surfaces

- Use the anchorbolts included
- Place rack in the desired location, ensuring correct clearance on all sides
- Place an 10mm drill through the 4 footing holes to mark the correct position
- Remove rack and drill to depth of 70mm. Clear holes of debris.  
**Do not drill over plumbing and/or electrical conduits, or through waterproof membranes that may be located just below surface level.**
- Using the screw bolts and a 15mm socket and wrench, secure the rack in place.

