

Stair Nosings





Enhancing public access one space at a time...

Architects and builders do an amazing job. They create buildings and spaces that are accessible to every Australian. We're just honoured to be part of the process.

Index

Stair Nosings	4
> What are stair nosings	4
> Types of stair nosings	5
> Which one should you use in your building?	6
> Are stair nosings mandatory?	6
> Luminance contrast	7
Installing Stair Nosings	8
> Installation Guide	8 - 9
Maintenance Tips for Stair Nosings	10

Stair Nosings

Each year slips, trips and falls result in thousands of preventable injuries. The most common ones are musculoskeletal injuries, cuts, bruises, fractures and dislocations, but more serious injuries can also happen. Although the elderly and young children are usually recognised as most at risk, falls on stairs are actually very common among young adults.

Stair nosings are problem solvers and problem preventers. Since the nose of a step is where people put their feet and weight on the stair, it is the part that tends to wear out first, resulting in the risk of slips and falls for people using the stairs. With stair nosings, the problem of worn stairs can be prevented.

Nosings can also help prevent the problem of slips and falls because of their anti-slip features. Commercial buildings, such as schools, universities, stadiums, and office complexes get a tremendous amount of pedestrian traffic each day. Building owners need to take every possible precaution to ensure the safety of these users and help protect themselves against litigation should an accident occur. Installing safety and visibility-enhancing aids such as stair nosings is the best way to fulfil this need while adding beauty and character to the building's décor.

You become a problem solver if your existing floor material is worn out from lack of stair nosing in the original installation and you retrofit the worn-out area by cutting out the bad part and replacing it with a Classic anti-slip stair nosing.

The simple act of adding quality stair nosings can help prevent slips and falls, add a sense of security, and help prolong the wear of both the stair tread and the floor-covering product used on the stairs.

What are stair nosings

Stair nosings are profiled strips of material, commonly aluminium, that are fitted on the edge of steps to assist in providing an anti-slip surface.

Types of stair nosings

When considering the type of stair nosing that will best fit your needs, look for both durability and aesthetic value. Depending on the application area, level of pedestrian traffic and the pedestrian type (adult, child, visually impaired, etc.), the type of nosing would differ.

Nosings can be made of Aluminium or Fibreglass.

Aluminium Nosing examples:

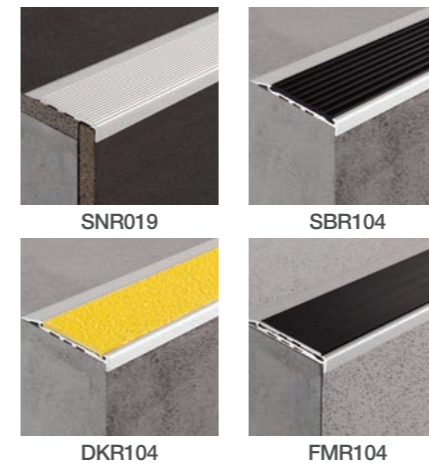

These are nosings that are either completely built of Aluminium or have a base made of Aluminium but have a space for an insert, which has anti-slip properties. These inserts could be made of Grit, polymer or Aluminium of a different colour.

Fibreglass Nosing examples:

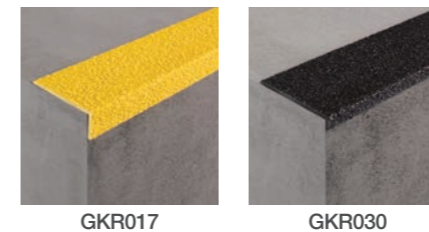

Fibreglass nosings are generally used in industrial or "back of house" areas.

These are the major types of nosing. The effectiveness and application of the nosing is dependent on their design. Based on the substrate that they need to be installed on, their design needs to ensure that they fit perfectly on the substrate and do not come off or become unstable while in use.

Different nosings for different substrates



In some of the application areas, such as theatres, for added safety, nosings are often provided with a photoluminescence strip, which makes the nosings glow in the dark, and thus enhance the safety.

Photoluminescence strip:

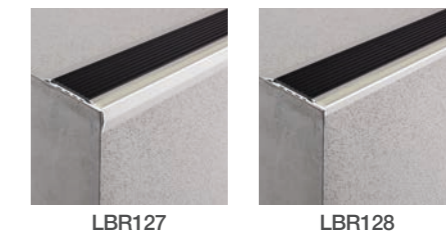

A photoluminescent strip can be inserted in both aluminium and fibreglass nosing. Such a strip charges under fluorescent tubes or natural light. This enables the strip to remain visible for even 12 hours of darkness. In case of power failure, or an emergency in which the building needs to be evacuated, the nosing would clearly show the step edges, thus adding to the safety. Installation of such nosing not only provides anti-slip properties to your stair edges, but also offers a visual reference to step edges for the partially sighted people.

Which one should you use in your building?

The type of nosing you should use in your stairways depends largely on the environment in which your stairways are placed. If you are looking for nosing to be placed in stairways of a commercial building, office, shopping mall, or any other public place, you can go for any one of the two main types. However, if you want to install nosing in stairs of industrial buildings, consider using fibreglass nosing. Being made up of fibreglass, it has outstanding resistance to corrosion, chemicals, heat, electricity, fire and several other elements. You can also install such nosing in stairs that are placed outdoors as these nosings are not affected by harsh weather. Fibreglass stair nosings are mechanically strong and very durable, making it suitable for industrial environment.

Are stair nosings mandatory?

AS1428.1 - is Australian Standard Design for Access and Mobility Part 1: General requirements for access – new building work - sets out minimum design requirements to provide access for most people with disabilities and addresses a wide range of building design elements.

Clause 11 of the Standard specifically addresses requirements for stairways and stair nosings and in this regard focuses almost entirely on promoting luminance contrast at the leading edge of step treads together with the avoidance of overhang at the front of stair treads.

The actual Standard has no mandatory power, however the Building Code of Australia (BCA) adopts AS1428.1 and requires mandatory compliance with that Standard and is enforceable by law. Clause D3.3(a)(ii) of the BCA states that in any new development, and in major refurbishment all stairways (except a fire stairway) must comply with Clause 11 of AS1428.1.

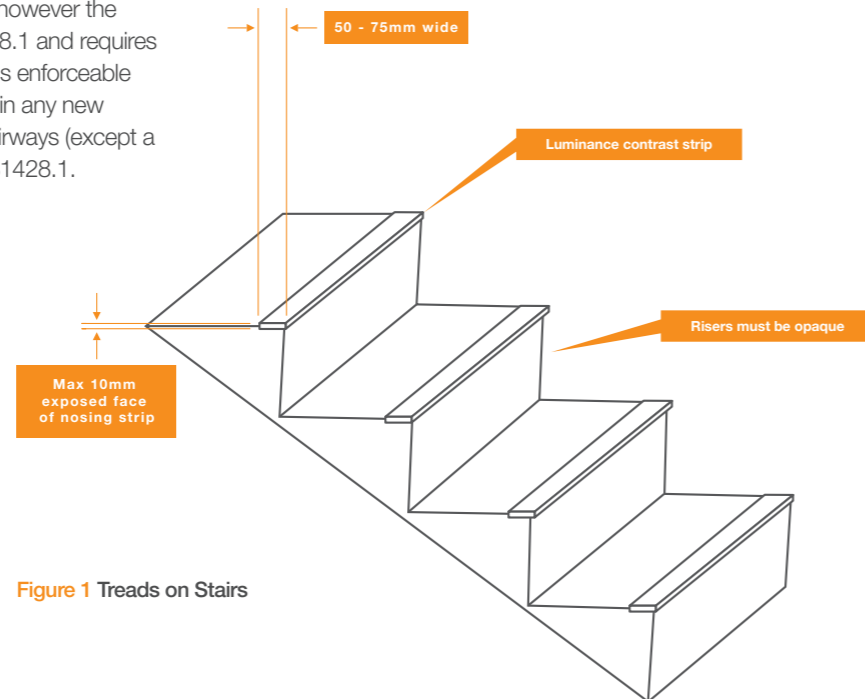

Figure 1 Treads on Stairs

According to AS1428.1:

- > Stair nosings must be continuous across the full width of the stair tread.
- > A luminance contrast strip that provides a strong visual clue of the tread/riser intersection must be included.
- > The luminance contrast strip must be between 50mm and 75mm wide and cannot be set back from the tread/riser intersection by more than 15mm.
- > The strip needs a luminance contrast of at least 30% with respect to the background material.
- > When located at the front of a stair nosing, the luminance contrast strip cannot extend down the riser more than 10mm.
- > Stair nosings are not allowed to project beyond the face of the riser.
- > Stair nosing profiles may have a sharp intersection or a radius up to 5mm, or up to a 5mm x 5mm chamfer at the tread/riser intersection.

Luminance contrast

Luminance contrast is defined in Standard 1428.1 as 'the light reflected from one surface or component, compared to the light reflected from another surface or component'. It is not simply the difference in the colour contrast but the difference in the light reflective properties of each colour.

Luminance contrast is preferred to colour contrast as it highlights the difference in the light/dark qualities of two adjoining surfaces rather than just their colours".

Below are examples of non AS 1428.1 compliant stairs:

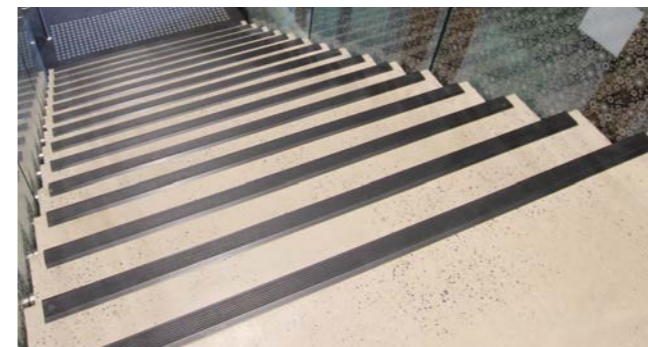
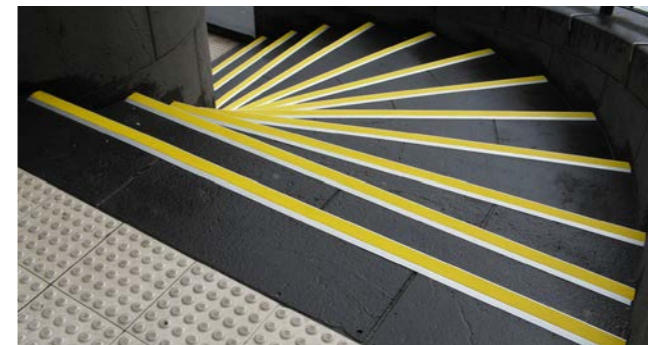

Depth of the riser: Where the luminance contrast strip extends down the front of the stair, the strip cannot be more than 10mm. This limitation is to avoid confusing the location of the leading edge of the tread. If the front of the nosing body is not a contrast or "blends in", and it is clearly differentiated from the luminance contrast strip, then the stair nosing body can extend any distance down the riser.

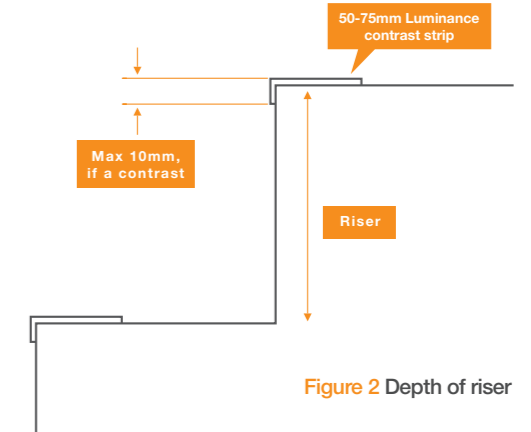

Figure 2 Depth of riser

Width of the luminance strip: The AS 1428.1 Standard prefers the strip to be one unbroken width, between 50mm and 75mm wide to maximise the contrast effect, however, minor interruption to that strip is tolerated provided that the interruption does not adversely impact the luminance contrast effect. As an example, a 50mm strip may be presented as two 25mm strips with a very thin division between but not presented as five 10mm strips with bold divisions between.

Nosings with luminance strips: To remain compliant with AS1428.1 the luminous contrast strip cannot be situated further than 15mm back from the front edge of the tread, so any glow feature should sit either immediately in front of or immediately behind the contrast strip while retaining the contrast strip width between 50mm and 75mm.

Installing Stair Nosings

Here are few things to consider while installing stair nosings:

1. Follow Building Code

It is important to research the code requirements for your specific application. You should follow the building code in terms of deciding on the length of the stair nosing. In addition, do not overextend the depth of the nose or face against the stated limit.

2. Ensure You Get A Good Fit

Generally, the aluminium stair nosing comes in long strips. So, it is required that you cut them as per the length of your stairs. It should fit perfectly to each step. Stair nosing increases the safety aspects of your stairs and installing ill-fitting stair nosings can create a safety hazard that you don't need.

3. Clean the Area Before Installing

Stair nosings are easy to install. You need to just glue down easily onto a variety of surfaces or use the countersunk drill holes to fix to your surface. But before installing the stair nosing, check the cleanliness of your stairs. For instance, if you are planning to install it in any commercial premises with heavy foot traffic, there are good chances of dirt or even cracks on the stairs. In that case, the nosing strip may not fit properly. So, make sure to clean the steps thoroughly as well as repair the cracks before installing stair nosings.

4. Use the Right Shape

The nosing should match the profile of your stairs as best as it can. Generally, the L-shaped aluminium nosing will fit most standard steps as they will create a perfect 90-degree angle. If your steps have a curved face it is recommended that you install flat aluminium nosing which sits flat on the stair edge and doesn't bend over the edge. This will provide non-slip properties, longevity on the stair edge and a streamlined look. Hence, before installation, you need to be aware that you need to choose the appropriate stair nosing according to your stair shape.

5. Ensure Tight Fitting

Stair nosing will serve the purpose only if they are fitted properly. The nosing strip must sit properly on the stair in a way that does not leave any space or gap in between the strip and the stair. For a better fit and look, you can also choose the depth and length of a stair nosing according to your stairs.

Installation Guide

For a greater understanding when installing, please refer to our **2018 Product Catalogue**:

Preparation

All surfaces should be flat, free from dust, paint, grease and moisture. Prepare the surface to be as smooth as possible. Any irregularities* must be corrected before installation of the stair nosing profile.

NOTE: It is imperative that damaged and worn treads are repaired using a suitable structural filling compound to provide a good base and prevent the stair nosing from rocking.

Layout

Layout the stair nosing profiles on the stairs, or use a straight edge or string line to ensure that all the stair nosings are properly centred on the steps, with the edges aligned. If required, trim the profiles using a drop saw with a high speed tungsten carbide blade.

NOTE: We strongly recommend allowing approx. 50mm gap from each end of the stair nosing profile to the stair stringer/walls, and also expansion gaps at approx. 3 metre intervals (where the nosings are in a long run) to assist with possible thermal expansion, and to allow for water egress. Please check the product supplied, and read the entire instructions before starting any installation, then follow the steps.

Mechanical Fixings (For concrete, timber, tiled, masonry, carpeted/metal substrates)

Figure A Using the pre-drilled stair nosings as templates, mark the hole locations on the step by spotting with a drill. **NOTE:** Do not put a screw in every hole, only one screw per 250mm. Recommended method is to install the stair nosings with the screws in a staggered pattern (one screw in front hole, one screw in back hole, repeating).

Figure B Once the holes have been drilled, ensure all surfaces are thoroughly clean and free of dust.

Figure C Insert plugs into holes and apply structural adhesive (CA290 or other CAG approved adhesive) to under-side of stair nosing profile (2 beads to the riser edge and beside screw holes along the entire length) to cushion any step variance and to prevent the nosing from rocking.

Figure D & E Place nosing down onto step and firmly screw into place using the screws provided. The stair nosings must be firm and the fasteners flush.

Adhesive Fixings (For stone, tiled, masonry, timber substrates)

Figure F Ensure that all surfaces are thoroughly clean.

Figure G Apply structural adhesive (CA290 or other CAG approved adhesive) to underside of stair nosing profile (at least 2 beads along the entire length including the riser edge) to cushion any variance and to prevent nosing from rocking.

Install Slip-resistant poly inserts (where supplied)

Pre-cut the insert approximately 30mm longer than required for the stair nosing. Carefully peel off the adhesive backing strip (**Figure H**) and start to mould the insert into place. **Do not stretch the insert.**

If in doubt as to correct installation methods, contact our customer service team on 1300 244 377

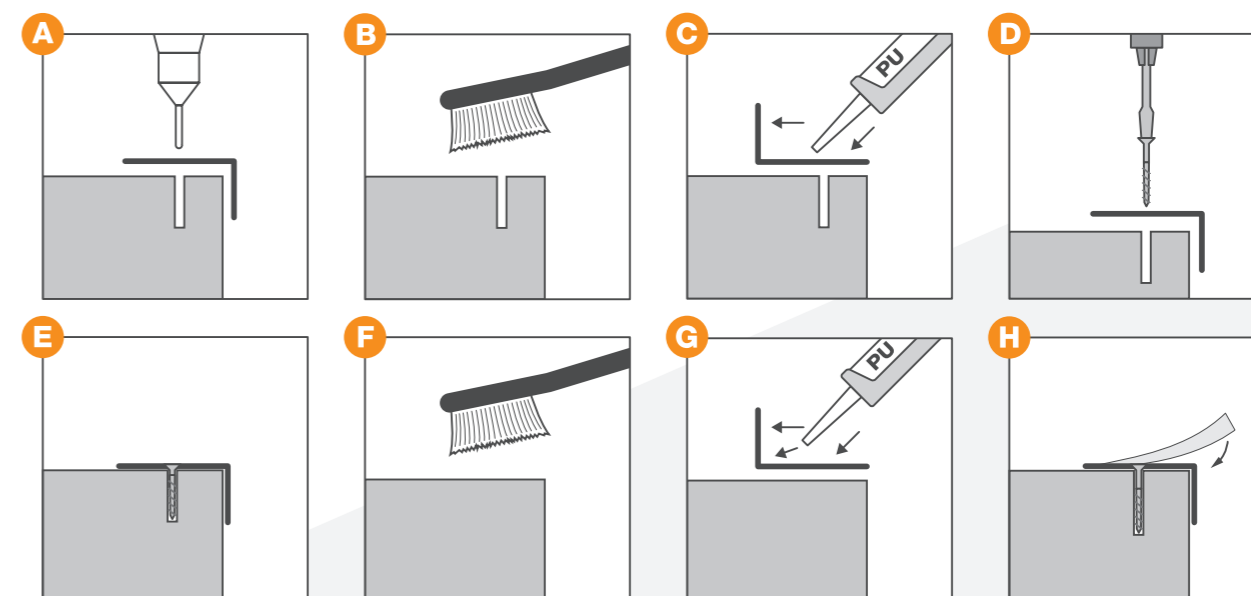



Maintenance Tips for Stair Nosings

To increase the life of your stair nosings, take care of a few things.

1. Regular Cleaning

If your stairs do not get heavy foot traffic, it is recommended that you clean the stair nosings on a weekly basis. But, if it is a commercial building and gets heavy foot traffic, it is better to clean them more often to ensure there is no dirt or grease build up. You can clean the inserts with a mild detergent diluted in water and carefully wipe the stair nosings with a damp cloth, followed by wiping it dry with a clean cloth.

2. Check for Signs of Damage

Regularly check your stairs and stair nosings for signs of wear and damage. Stair nosings can be replaced as wear and tear starts to show, ensuring the safety standards in your environment are kept very high and this way you will save on large repair costs.

Our Ecosystem

To deliver on our promise, we rely on and work very closely with many architectural and construction firms including **Lend Lease, Probuild, Multiplex, John Holland, ADCO Constructions, Woods Bagot, Conrad Gargett, Thomson Adsett, Architectus, Bates Smart, The Buchan Group, Cox Architecture and Silver Thomas Hanley, Icon, Built, Watpac, Hansen Yuncken and many more.**

What they say

"Classic have a great operation here and are the best in town. No one comes close."

"I always come to Classic whenever I need advice on floor safety products, because they are always so happy to share it, and offer me solutions."

"Classic products are great - they are properly designed, they work well, and they last."

"I really appreciate the way Classic operates. I wish others were more like them!"

Our Projects

We deliver and install public safety and access solutions for many industries including Healthcare, Hospitality, Educational Institutions, Public Infrastructures, Aged care, Residential, Commercial Offices, Entertainment & Sports, Travel & Transport, and many more.

